

ToolSmith Engineered Solutions

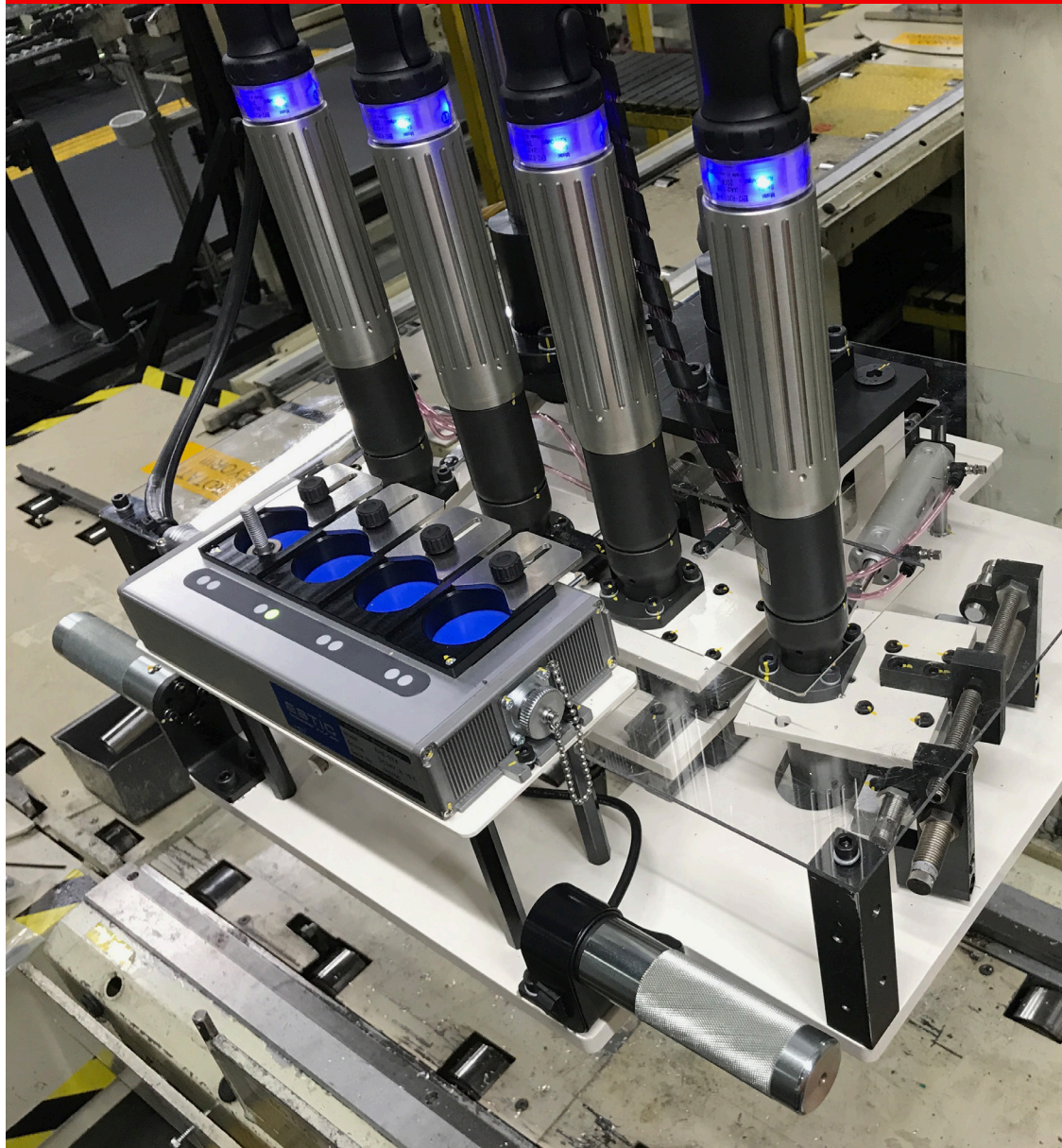

Torque Systems

Handling Devices



Lift Assists

Tool-Smith develops custom devices to enable operators to lift, manipulate, and transfer loads quickly, safely, and ergonomically.

Gripping Options

We can incorporate mechanical, magnetic, vacuum, or cylinder actuated clamping to grasp the load. This flexibility ensures our devices can lift any part without marring or otherwise damaging it, and without slowing down the operator.



Mechanical clamp

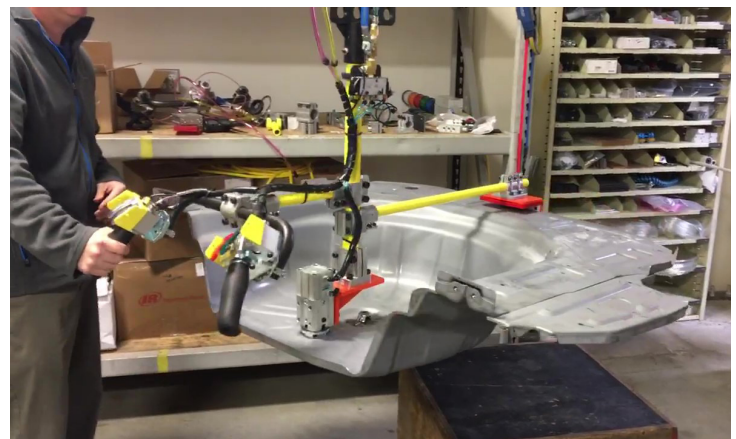

Pin clamp gripper

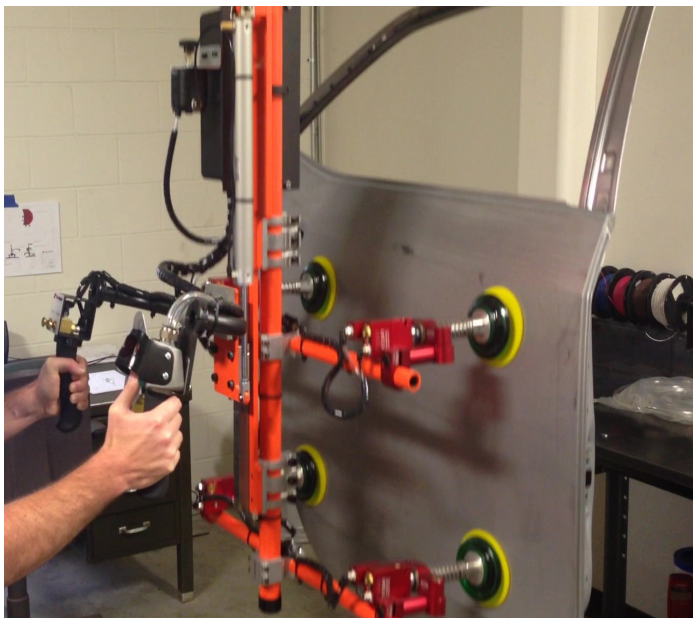

4 Vacuum point assist

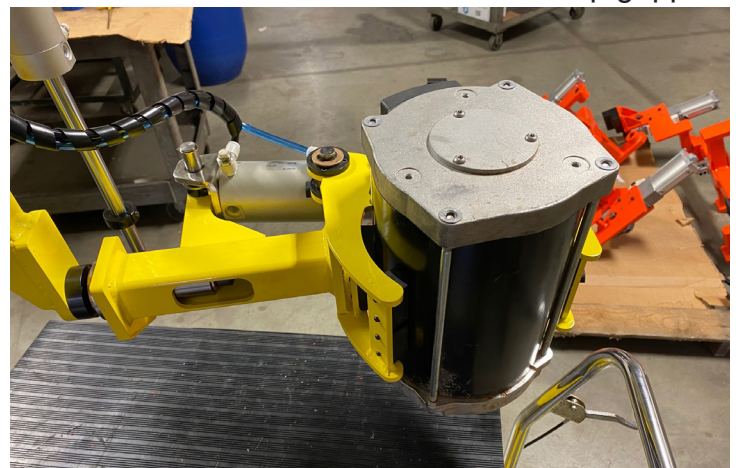

Pneumatic clamping device

Actuation

In addition to standard straight transfer lifting devices, Tool-Smith builds end effectors that can pivot, rotate, swivel, or otherwise position a part. Adjustable devices allow one handling device to lift multiple, different sized parts. For applications with faster movement requirements, we can incorporate intelligent ergonomic control handles to deliver weightless manipulation.



Cylinders tilt part upward 90 degrees, while weightless extended handles provide operator comfort



Cylinders tilt dashboard panel into an upright position



Pneumatic Oscillator- 180 Degree Glass Rotate Assist

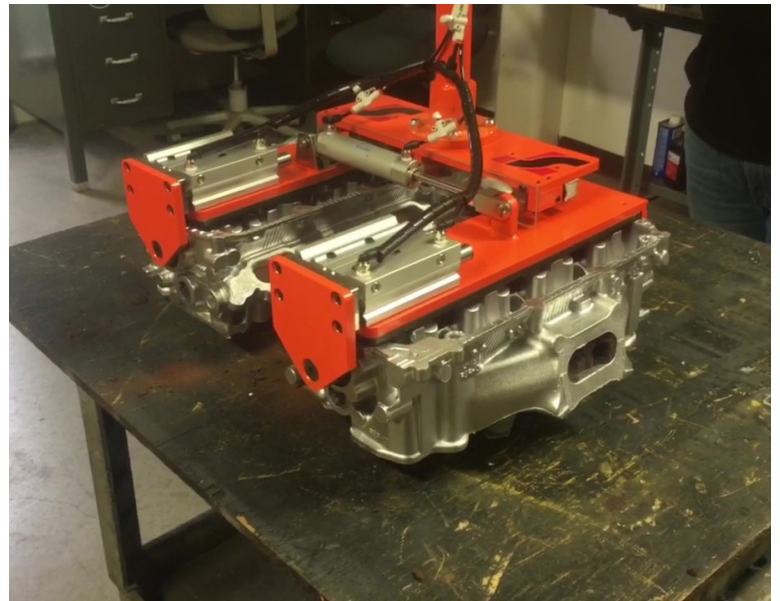

Cylinders shift parts closer together after clamping

Offsets

At times obstructions prevent picking up parts from directly overhead. These applications require load assists designed to handle offset loads. Rigid load trolleys, torque tubes and articulating arms can be used to handle offset loads and reach applications.



Rigid vertical arm with offset clamp Tooling



Rigid trolley and parallel link articulating arm add stability to this device



Pneumatic swing arm clamp

Safety Features

- Safety interlocks prevent accidental release of loads
- Load deflection calculations determine weight limits
- “Up Disabled Circuit” disables lift until gage senses proper vacuum has been achieved

Specialty Applications



Vacuum Tube Lifts



Less complicated off the shelf lean solutions



High capacity vacuum lifts



Floor Mounted Systems

Automation

Tool-Smith can design, build, and install fully autonomous material handling systems for repetitive operations requiring speed and precision .



This automated 4 spindle torque station fastens 4 bolts in unison when the conveyor presents the part to be assembled, all without operator guidance.



This device moves work pieces from an incoming conveyor, rotates them to the correct position for the next operation, and places them onto the next conveyor line.

***Let's
Get
Started!***

Ready to start building a lifting solution? On the following pages you'll find a Material Handling Application Data Sheet you can use to describe the parameters of your application, either on your own or with a Tool-Smith representative on-site at your facility. The Application Data Sheet gives our engineers a road map to begin designing a lift assist to fit your needs.



Material Handling Application Data Sheet

1. CUSTOMER INFORMATION (END USER):

Company: _____ Contact: _____ Title: _____
 Address: _____ Phone: _____ Fax: _____
 Country: _____ Email: _____
 Other Contact Info: _____

2. FIXTURE BUILDER / LINE INTEGRATOR:

Company: _____ Contact: _____ Title: _____
 Address: _____ Phone: _____ Fax: _____
 Country: _____ Email: _____
 Other Contact Info: _____

3. APPLICATION INFORMATION:

Number of different parts to be handled: _____

Description of part(s) to be handled: _____

Drawings of part(s) provided by customer: Yes No Drawing format: _____

Part(s) Available for Runoff / Tryout: Yes No Picture/ Video of the work area? Yes No

Picture/ Video of the part being handled today? Yes No

If different, are parts run in batch or random sequence: Batch Random

Dimensions of part:

Description:	Weight:	Height:	Width:	Length:	I.D.	O.D.	Please attach list of additional sizes if applicable	

Surface Finish: Wet Oily Dry Hot °F °C Class A Fragile Textured Other

If other explain: _____

Description of Current Process / Sequence of Operation: _____

Production Rate: Jobs per hour: _____

What is the justification for Manipulation: (Check all that apply)

Reduce Manpower Ergonomics Safety New Product New Work Cell
 Other

Material Handling Application Data Sheet

4. PART PICK UP:	FIRST PICK UP:	SECOND PICK UP:
* What is the part being picked up from:		
Are there obstructions around part at pick up:	<input type="checkbox"/> Yes <input type="checkbox"/> No	<input type="checkbox"/> Yes <input type="checkbox"/> No
* If yes, specify:		
* Suggested area for attaching device to part:		
* Areas of the part that should not be touched:		
* Part Orientation at pick up (operator's perspective):		
* Part elevation at pick up (dimension):		

*Provide necessary sketches where * appears*

5. PART SET DOWN:	FIRST SET DOWN:	SECOND SET DOWN:
* What is the part being set down into / onto:		
Are there obstructions around part at set down:	<input type="checkbox"/> Yes <input type="checkbox"/> No	<input type="checkbox"/> Yes <input type="checkbox"/> No
* If yes, specify:		
* Part Orientation at set down (operator's perspective):		
* Part elevation at set down (dimension):		

*Provide necessary sketches where * appears.*

6. HANDLING DEVICE FEATURES:	
<u>Style of Handling Device:</u>	
<input type="checkbox"/> Clamp <input type="checkbox"/> Vacuum <input type="checkbox"/> Probe <input type="checkbox"/> Hook <input type="checkbox"/> Trap <input type="checkbox"/> Other	
<u>Type of Controls:</u>	<u>Single Set or Dual Set Controls:</u>
<input type="checkbox"/> ZA <input type="checkbox"/> EA <input type="checkbox"/> 2PS <input type="checkbox"/> BA <input type="checkbox"/> Electronic	<input type="checkbox"/> Single <input type="checkbox"/> Dual

* Motion of Handling Device:

Straight Transfer

If not, indicate the desired motion shown below:

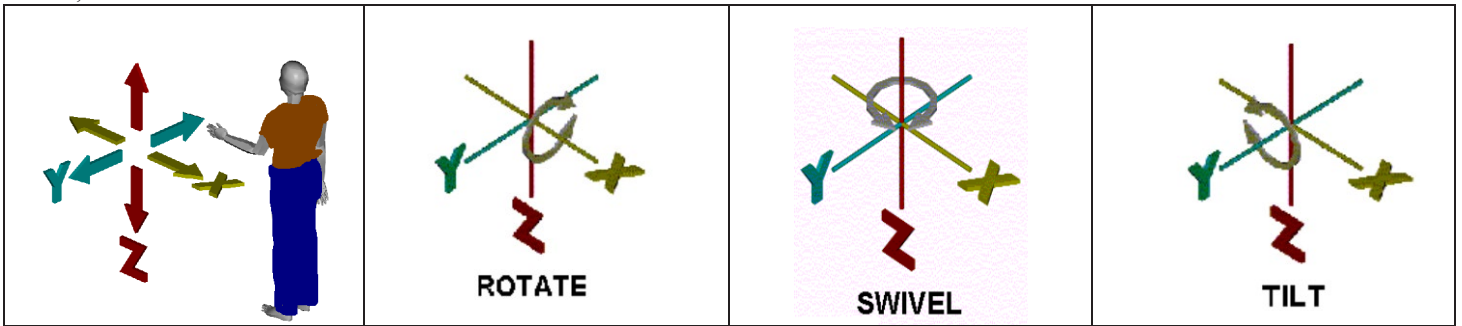

Operators perspective	<input type="checkbox"/> Rotate Degrees: _____ <input type="checkbox"/> Power <input type="checkbox"/> Manual	<input type="checkbox"/> Swivel Degrees: _____ <input type="checkbox"/> Power <input type="checkbox"/> Manual	<input type="checkbox"/> Tilt Degrees: _____ <input type="checkbox"/> Power <input type="checkbox"/> Manual
-----------------------	---	---	---

* **Specify rotation and / or tilt as viewed by the operator:**

Provide necessary sketches where * appears.



Material Handling Application Data Sheet

7. ENVIRONMENT:

Air Pressure: 60-70 PSI 70-80 PSI 80-90 PSI Other PSI

Electrical Supply: 115 VAC If other, please specify _____

Operating Conditions:	Conditions that require customer mfg. Specifications:
<input type="checkbox"/> Hot <input type="checkbox"/> Cold	<input type="checkbox"/> Corrosive <input type="checkbox"/> Dusty <input type="checkbox"/> Clean Room <input type="checkbox"/> Food / Beverage <input type="checkbox"/> Medical
° F ° F	
° C ° C	

Elevation from floor to bottom of header steel or Enclosed Rail: _____

Type of Rail: _____

8. MOUNTING OPTIONS:

Balancer Style:
 150 lb (68 Kg) 200 lb. (90 Kg) 350 lb. (158 Kg) 500 lb. (227 Kg) Intelift: Other: _____

Arm Style:
 400 600 700 701 713 720

9. ADDITIONAL REQUIREMENTS:

Are detail drawings required? (extra charge) No Yes If yes, indicate the desired CAD format _____

Type of review if required: On Site Video Special None

10. SPECIAL REQUIREMENTS OR CUSTOMER SPECIFICATIONS:

Prepared by: _____ Date: _____

Fastening Solutions

Tool-Smith creates multi-spindle powerheads to match any bolt configuration, as well as unique torque arms and fixtures to protect operators from DC tools' torque reactions.



Multi-Spindle control enclosure



Multi-Spindle Tool Configuration

Adjustable Centers

Adjustable centers save money on assembly stations running several different parts. To accommodate multiple bolt patterns, tools move along adjustable tracks either manually or with powered assistance.



Multi-Spindle Device with Movable Centers

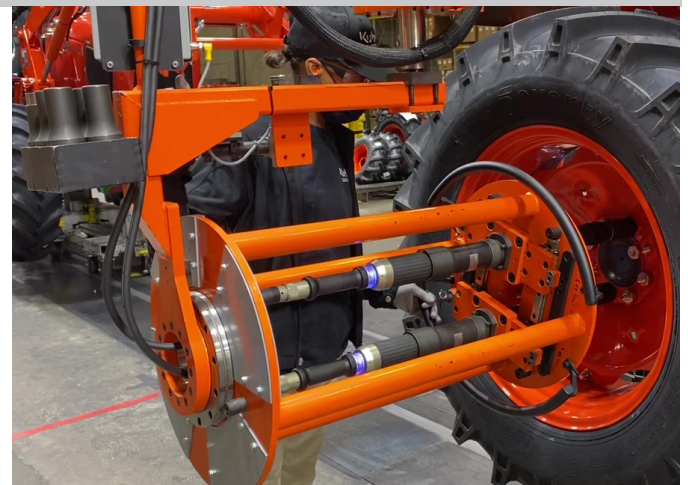

2 spindle machine with changing centers

More Than Tools

Touch screens, position sensors, and socket trays are just some of the electrical PLC controlled accessories that can be used to select the proper torque for the part being assembled.

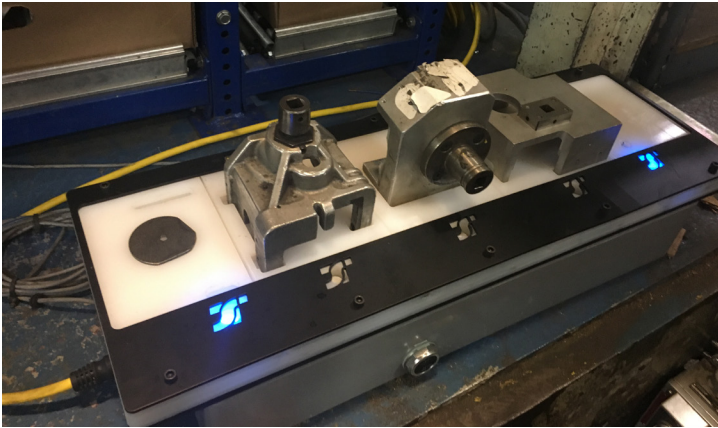

Custom Socket Tray



Light boxes

Precise Alignment

Tool-Smith designs torque tube systems for applications that require precise alignment or high torque. The system shown incorporates a custom tool holder to align the tool almost perfectly perpendicular to the work. The dual bridge suspension adds extra stability to maintain the vertical position throughout the rundown.



Assembly Fixtures



In this application, the PLC only enables the operator to proceed when proximity sensors determine that all parts are correctly placed on the fixture. Two-handed anti-tie-down controls protect the operator's hands from being caught in the machine. The torque reaction arm contains sensors to determine the tool's position in three dimensional space. If the tool is positioned over the correct bolt, the controller selects the appropriate torque and enables the tool for the operator to run down the fastener. E-Stop and manual reset controls provide extra safety and flexibility.



Hinge Install Fixture



This tap machine protects operators by disabling the device if any of the enclosures are opened.

Crash carts

Tool-Smith's Crash Carts allow quality teams to bring precision fastening wherever rework needs to be done. All the necessary DC tools and controllers are mounted on a wheeled cart, and the correct program for the application can be automatically loaded into the tool by pulling the corresponding socket from the socket tray on top.



Robotics

For applications that are ergonomically challenging or otherwise difficult for human operators, we can integrate coworking robots into the process. Gripping devices or torque tools can be attached to the robot arm for a wide array of manufacturing applications.

***Let's
Get
Started!***

Ready to start building a fastening solution? On the following pages you'll find a Fastening Solutions Application Data Sheet you can use to describe the parameters of your application, either on your own or with a Tool-Smith representative on-site at your facility. The Application Data Sheet gives our engineers a road map to begin designing a torque system to fit your needs.

Preliminary Specification Sheet - Request for Quote (RFQ)

Project Information			
Customer	Application	Sales Rep	Integrator
Local Project Number	Global Project Number	RFQ Date	Quote Required Date

Joint Information				
No. of Fasteners	Fastener Type (Free Spinning, Prevailing Torque or Thread Forming)	Joint Type Hard, medium, soft (≤30°, 100°, ≥200°)	Socket size	Duty Cycle (cycles/min)

Tightening Strategy (describe, include any fault re-work strategies)
Rework strategy: back-out spindle <input type="checkbox"/> back-out companion spindle <input type="checkbox"/> back-out all spindles <input type="checkbox"/> # of re-tries: <input type="text"/>

System Specification								
No. of Spindles/Tools	Spindle Model No.	Max. Torque	Torque Units	Controller Model No.	Software		Cable Lengths (M)	
					Version	License Quantity	Tool Cables	Extension Cables

Controller Information			
Controller Mounting Enclosure or Rack	Door Mounted Tray and/or Industrial PC (enclosure only)	Customer Power	Other (air conditioner etc)

Additional Services/Accessories Required on Quote (mark (click) box if required)			
Services		Accessories	
Installation <input type="checkbox"/>	Run-Off at TS <input type="checkbox"/> on-site <input type="checkbox"/>	Light Tower <input type="checkbox"/>	Light Box <input type="checkbox"/>
Stand-By Service <input type="checkbox"/>	Training <input type="checkbox"/>	Assembly Selector Switch 4 <input type="checkbox"/>	8 <input type="checkbox"/>
Application/Parts Testing <input type="checkbox"/>	Extended Warranty (____ years) <input type="checkbox"/>	Socket Tray 4 <input type="checkbox"/>	8 <input type="checkbox"/>
Other(describe) <input type="checkbox"/>		Remote Handle <input type="checkbox"/>	Dummy handle <input type="checkbox"/>
		Accessory Cable <input type="checkbox"/> Model No.:	
		E-Stop Switch <input type="checkbox"/>	Palm Reset Switch <input type="checkbox"/>
		Other (describe) <input type="checkbox"/>	

Customer Specifications and Requirements
Include details of anything special here, Examples: Custom I/O, Custom Protocol, Custom Paint, and Customer Specifications, Space limitations, non-standard or special items.

Send Quote to	RFQ Requested by	Delivery required by
<input type="checkbox"/> Integrator	Name:	<input type="checkbox"/> Integrator:
<input type="checkbox"/> Customer	Territory #:	<input type="checkbox"/> Customer:
<input type="checkbox"/> TS Rep		<input type="checkbox"/> TS Location:

Preliminary Specification Sheet - Request for Quote (RFQ)

Power Head Description

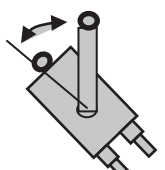
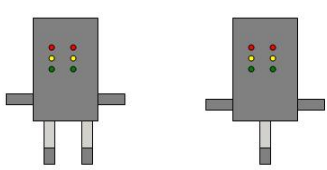
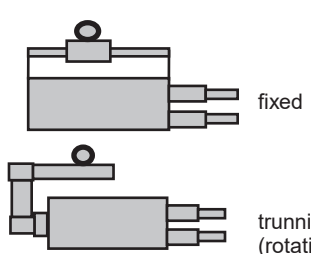
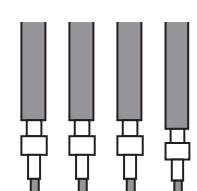
<p>vertical (or angled from vertical) pivoted configuration</p>  <p>Angle = degree (if applicable)</p> <p><input type="checkbox"/> check box for fixed spindles <input type="checkbox"/> check box for adjustable spindles</p>	<p>vertical configuration</p>  <p>2-spindle examples shown 'side-by-side' 'front-to-back'</p> <p><input type="checkbox"/> check box for 'side-by-side' <input type="checkbox"/> check box for 'front-to-back'</p> <p><input type="checkbox"/> check box for fixed spindles <input type="checkbox"/> check box for adjustable spindles</p>	<p>horizontal configuration</p>  <p>fixed trunnion (rotating)</p> <p>Angle = ± degrees (trunnion)</p> <p><input type="checkbox"/> check box for fixed spindles <input type="checkbox"/> check box for adjustable spindles</p>	<p>Loose spindles For mounting by integrator or customer</p>  <p><input type="checkbox"/> check box for loose spindles</p>
---	---	---	--

Bolt Pattern Configuration

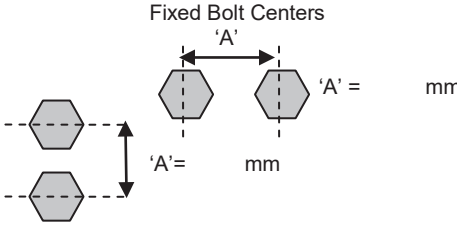
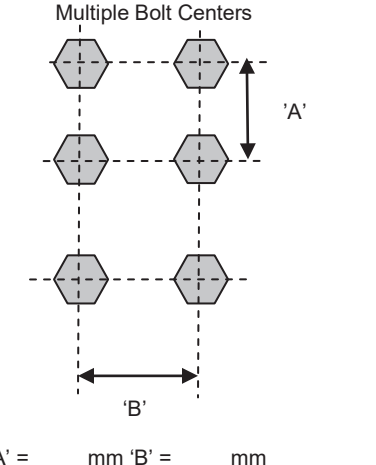
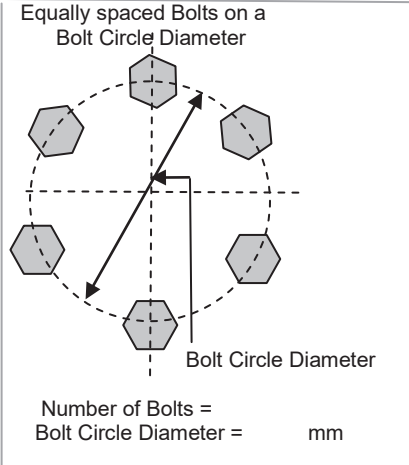
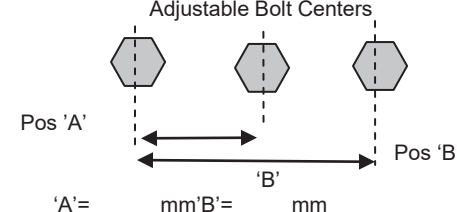
<p>Fixed Bolt Centers</p>  <p>'A' = mm</p> <p>'A' = mm</p>	<p>Multiple Bolt Centers</p>  <p>'A' = mm</p> <p>'B' = mm</p>	<p>Equally spaced Bolts on a Bolt Circle Diameter</p>  <p>Bolt Circle Diameter</p> <p>Number of Bolts = Bolt Circle Diameter = mm</p>
<p>Adjustable Bolt Centers</p>  <p>Pos 'A'</p> <p>Pos 'B'</p> <p>'A' = mm 'B' = mm</p>	<p>'A' = mm 'B' = mm</p>	

Tool Suspension System

(Please indicate dimensional details of floor to work piece to rail etc where relevant)

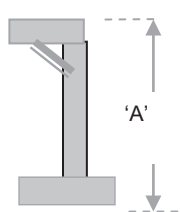
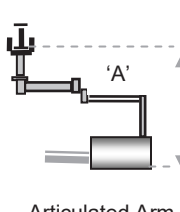
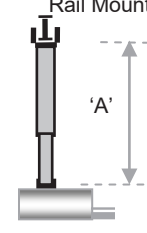
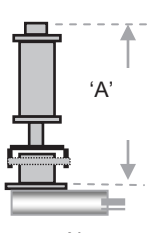
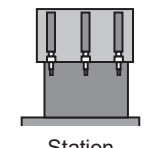
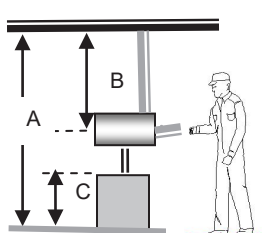
<p>Rail Mount</p>  <p>Spring Balancer</p>	<p>Floor Mount</p>  <p>Articulated Arm</p>	<p>Rail Mount</p>  <p>Articulated Arm</p>	<p>Rail Mount</p>  <p>Torque Tube</p>	<p>Rail Mount</p>  <p>Air Cylinder</p>	<p>Floor Mount</p>  <p>Station Mounted</p>	<p>Dimensions (if applicable)</p> 
<p><input type="checkbox"/> Select</p>	<p><input type="checkbox"/> Select</p> <p>'A' = mm</p>	<p><input type="checkbox"/> Select</p> <p>'A' = mm</p>	<p><input type="checkbox"/> Select</p> <p>'A' = mm</p>	<p><input type="checkbox"/> Select</p> <p>'A' = mm</p>	<p><input type="checkbox"/> Select</p>	<p>'A' = mm 'B' = mm 'C' = mm</p>



Locations

Birmingham Headquarters

1300 4th Avenue South
Birmingham, AL 35233
Phone: (205) 323-2576

Mobile

927 Lakeside Drive
Mobile, AL 36693
Phone: (251) 661-0404

Nashville

665 Massman Drive
Nashville, TN 37210
Phone: (615) 883-4833